

Sharing crystal with an MCU

nWP-011

White paper v1.1

1 Introduction

This white paper gives guidelines on how a crystal can be shared between an nRF transceiver from Nordic Semiconductor and an external microcontroller unit (MCU). The nRF24L01+ (and the nRF24L01) has been used as an example in this paper, and all the data is based on the datasheet of that device. However, we refer only to the nRF24L01+ in the rest of this document. In case other nRF devices are to be used, all necessary data can be found in their corresponding datasheets.

2 Crystal from MCU used to feed nRF24L01+

In this setup the MCU controls the startup of crystal, feed the clock to nRF device, and also specify most of the crystal requirements. This is the recommended setup, based on the advantages listed at the end of this chapter.

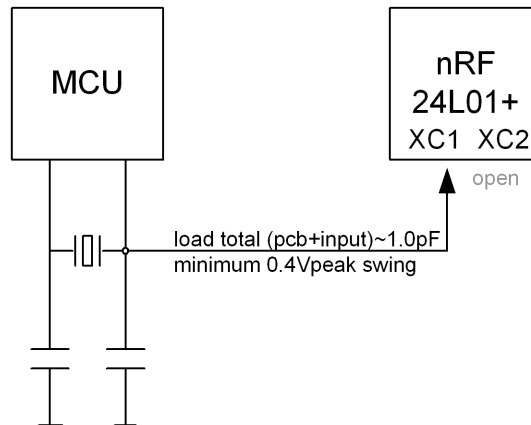

Figure 1. MCU feed nRF24L01+

The nRF24L01+ crystal oscillator is amplitude regulated. To achieve low current consumption and also good signal-to-noise ratio when using an external clock, it is recommended to use an input signal larger than 0.4 V-peak. When clocked externally, XC2 is not used and must not be connected.

The input signal must not have amplitudes exceeding any rail voltage, but any DC voltage within this is OK. Exceeding rail voltage will activate the ESD structure and the radio performance is degraded below specification.

When the MCU drives the nRF24L01+ clock input, the requirement of load capacitance C_L is set by the microcontroller only. The frequency accuracy of $\pm 60 \text{ ppm}^1$ is still required to achieve a functional radio link. The nRF24L01+ will load the crystal by 1.0 pF^1 at XC1 in addition to the PCB routing.

Advantages with this kind of setup are summed up in the following bullet points:

- The MCU can control the startup of the crystal oscillator.
- The MCU will ensure a large signal ($> 0.4 \text{ V-peak}$) from crystal.
- C_L can be chosen freely depending on MCU requirements (a high value of C_L leads to higher current consumption).

1. This data is nRF24L01+ specific, and must be checked if other nRF devices are to be used.

Requirements	MCU	nRF24L01+
Frequency		16 MHz ^a
Tolerance		+/- 60 ppm ^a
C _{L max}	X	
C _{O max}	X	
ESR _{max}	X	

a. This data is nRF24L01+ specific, and must be checked if other nRF devices are to be used.

Table 1. Crystal requirements set by respective device (see [Figure 1.](#))

3 Crystal from nRF24L01+ used to feed MCU

In this setup the nRF24L01+ controls the crystal startup, feeds the MCU clock, and also sets all requirements to crystal specifications.

The nRF device needs to be set in power up mode before the crystal oscillator starts. This means that the MCU must be able to do this before it receives the clock from the nRF device. This is not a recommended setup and there are no advantages with this kind of setup.

4 Conclusion

The advantages of sharing a crystal with an MCU are fewer components and smaller PCB board, which means lower cost to bill of materials. Also it's possible to use a crystal with other specifications, by feeding the clock from an MCU.

An MCU can be used to feed clock to the nRF24L01+, however the opposite is not recommended. This is mainly due to the fact that the nRF24L01+ is by default in power down mode, and needs to be configured with power up bit¹ high, before it will start up its crystal oscillator.

1. This data is nRF24L01+ specific, and other nRF devices might have power up as an input pin.

Liability disclaimer

Nordic Semiconductor ASA reserves the right to make changes without further notice to the product to improve reliability, function or design. Nordic Semiconductor ASA does not assume any liability arising out of the application or use of any product or circuits described herein.

Life support applications

Nordic Semiconductor's products are not designed for use in life support appliances, devices, or systems where malfunction of these products can reasonably be expected to result in personal injury. Nordic Semiconductor ASA customers using or selling these products for use in such applications do so at their own risk and agree to fully indemnify Nordic Semiconductor ASA for any damages resulting from such improper use or sale.

Contact details

For your nearest dealer, please see <http://www.nordicsemi.com>

Receive available updates automatically by subscribing to eNews from our homepage or check our website regularly for any available updates.

Main office:

Otto Nielsens veg 12
7004 Trondheim
Phone: +47 72 89 89 00
Fax: +47 72 89 89 89
www.nordicsemi.com



RoHS statement

Nordic Semiconductor's products meet the requirements of Directive 2002/95/EC of the European Parliament and of the Council on the Restriction of Hazardous Substances (RoHS). Complete hazardous substance reports as well as material composition reports for all active Nordic products can be found on our web site www.nordicsemi.com.

Revision History

Date	Version	Description
June 2011	1.1	Updated template, chapter 2 and replaced the product name "nRF24L01" with "nRF24L01+"
May 2006	1.0	